

FACE

Automatic Doors

USER INSTRUCTIONS FOR SLIDING DOORS

AWARDED WITH THE
SPECIAL INNOVATION PRIZE R+T 2018 FOR ENERGY EFFICIENCY



SL3	LIGHT	SL6HA	HERMETIC-ADVANCED
SL4A-SL5A-SL6A	ADVANCED	SL6HB	HERMETIC-BIG
SL4E-SL5E-SL6E	EMERGENCY	SLTA	TELESCOPIC-ADVANCED
SL5H-SL6H	HEAVY	SLTB	TELESCOPIC-EMERGENCY
SL6B	BIG		

1. CORRECT USE OF THE AUTOMATIC SLIDING DOOR

The automations for automatic sliding doors have been designed and constructed in accordance with European standard EN 16005, also the innovative and advanced electronic control system makes the door safer, as the maximum forces developed are limited to non-hazardous values.

It's still need to be observed the following precautions to ensure safety in relation to intended use: pedestrian traffic of people.

1.1 GENERAL SAFETY INSTRUCTION

These warnings are an integral and essential part of the product and must be supplied to the user. Read them carefully as they contain important information regarding the safe use and maintenance. You must keep these instructions and pass them on to subsequent users of the system.

This product must be used only for the purpose for which it is designed. Any other use is considered improper and therefore dangerous. The manufacturer can't be held responsible for any damage caused by improper, incorrect or unreasonable use.

Avoid the rest of the people in the vicinity of the area occupied by the stroke of the sliding doors. Do not obstruct the motion of the automatic sliding door as it may cause dangerous situations.

It's forbidden run toward a closed door , as the reaction time of the opening devices may be insufficient to avoid a collision.

This product is not intended for use by persons (including children) with reduced physical, sensory or mental capabilities, or lack of experience and knowledge, unless they have been given supervision or instruction concerning use of the product by a person responsible for their safety. Children should be supervised to ensure that they do not play with the product.

In the event of failure or malfunction of the product, disconnect the power supply , avoid any attempt to repair or intervene directly and contact only qualified personnel . Failure to comply with the above may create a hazardous situation.

To ensure the efficiency of the system and its proper functioning is essential to follow the manufacturer's instructions; the periodic maintenance of automatic sliding door must be performed by qualified personnel. In particular, it is recommended that the periodic verification of the correct operation of all safety devices. All installation , maintenance and repair work must be documented and made available to the user.

1.2 RESTRICTIONS OF USE AND RESIDUAL RISKS

The European standard EN 16005 defines clearly what are the main hazards and the necessary protection to secure the use of an automatic sliding door in standard conditions. Nevertheless, there may be particular situations where it is necessary to assess the possible risks and adopt the related solutions for the protection or risk reduction.

For example, the particular installation can be generated by: the architectural requirements, the type of use, from the environment of use, from the spaces in the building, the type of users, etc.

It's the installer duty to identify and assess these risks and notify the owner of the solutions adopted, including the existence of residual risks or the need for restrictions on use, filling in the following table.

Rif.	Residual risk	Adopted solution

2. STANDARD INSTALLATION

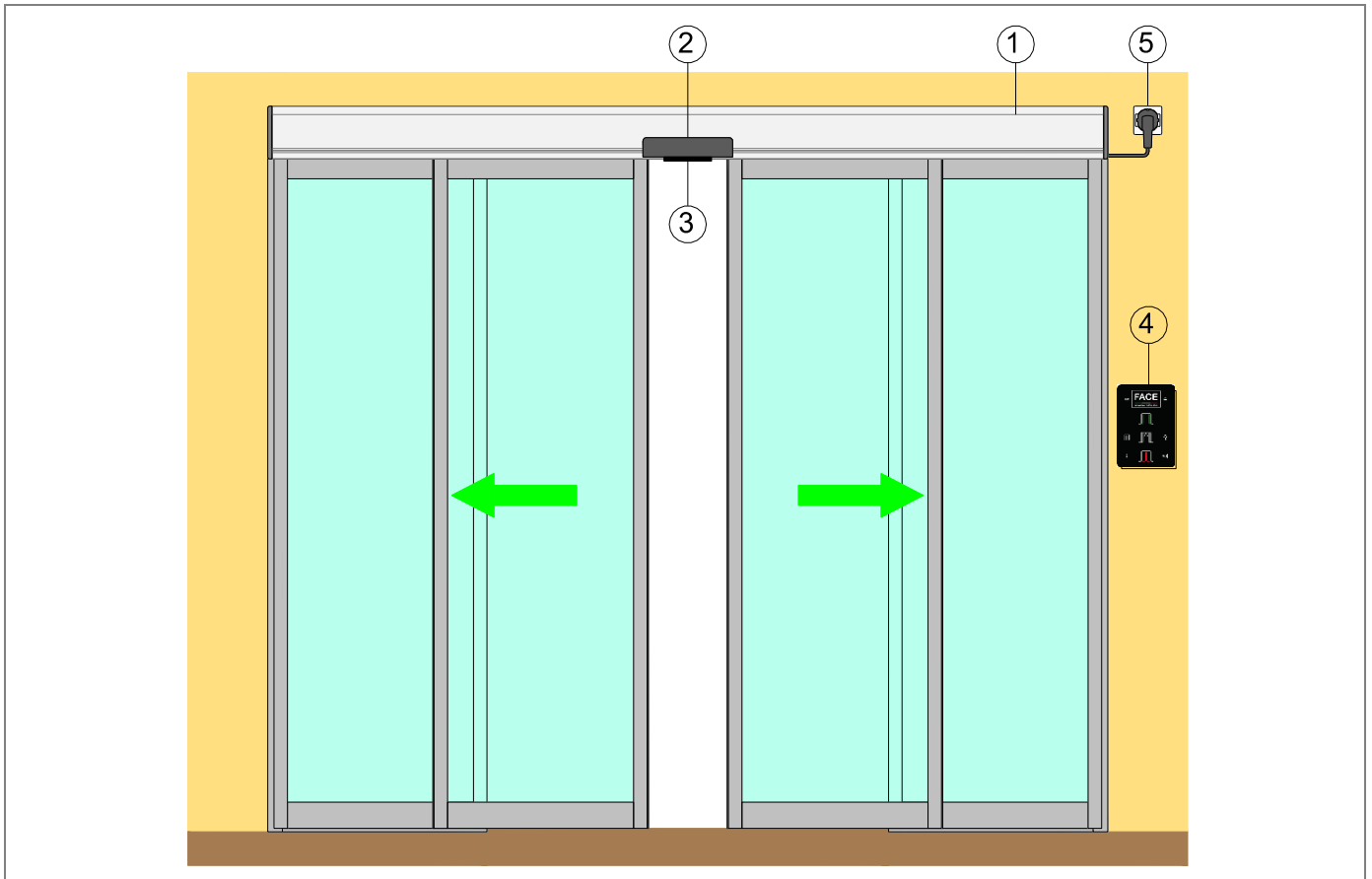

Rif.	Code	Description
	SL3L220 – SL3L266	SL3L automation (Light) for sliding doors
	SL4A220 – SL4A266	SL4A, SL5A, SL6A automation (Advanced) for sliding doors
	SL4E220 – SL4E266	SL4E, SL5E, SL6E automation (Emergency) for sliding doors
	SL5H220 – SL5H266	SL5H, SL6H automation (Heavy) for sliding doors
1	SL6B236 – SL6B266	SL6B automation (Big) for sliding doors
	SL6HA120L(R) – SL6HA144L(R)	SL6HA automation (Hermetic-Advanced) for hermetic sliding doors
	SL6HB120L(R) – SL6HB144L(R)	SL6HB automation (Hermetic-Big) for hermetic sliding doors
	SLTA230 – SLTA266	SLTA automation (Telescopic-Advanced) for telescopic sliding doors
	SLTE230 – SLTE266	SLTE automation (Telescopic-Emergency) for telescopic sliding doors
2	OSD1, OSD3, OSD4, OSD5, OSD6 OSD4, OSD7	Unidirectional and safety opening sensor Unidirectional and safety opening sensor for Emergency exit (N.B. To ensure the safety of the doorway, are needed 2 sensors, one on each side)
3	SL5FS	Device for fixing sensors
4	FSD1, FSD4	Electronic function selector with transponder key
-	SL5BD, SL5BD1, SL5BD2	Battery power device for emergency operation
-	SL5LD	Bistable locking device
5	-	Power cable for connection of the automation

Note: Components and codes are those most commonly used in systems for automatic sliding doors. The full range of equipment and accessories is also available in the sales list.



The given operating and performance features can only be guaranteed with use of FACE accessories and safety devices.



This is a translation of the original Italian user instruction. All data and information contained in this manual have been drawn up and checked with the greatest care. However FACE cannot take any responsibility for eventual errors, omissions or inaccuracies due to technical or illustrative purposes.

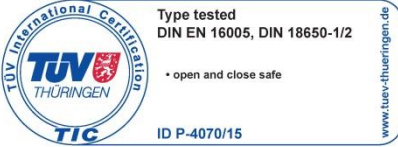

FACE reserves the right to make changes and improvements to their products. For this reason, the illustrations and the information appearing in this document are not definitive.



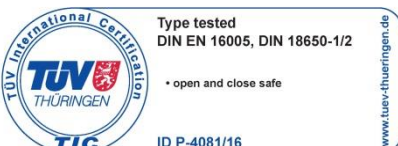

This edition of the manual cancels and replaces all previous versions. In case of modification will be issued a new edition.





3. TECHNICAL DATA



Features	SL4A – SL5A – SL6A	SL4E – SL5E – SL6E
Automation type	ADVANCED	EMERGENCY
Certification	 <p>Type tested DIN EN 16005, DIN 18650-1/2</p> <ul style="list-style-type: none"> • open and close safe <p>ID P-4070/15</p>	 <p>Type tested DIN EN 16005, DIN 18650-1/2, AutSchR</p> <ul style="list-style-type: none"> • escape route safe • open and close safe <p>ID P-4071/15</p>
Max product dimensions: Height x Depth x Maximum length	125 x 156 x 6600 mm	125 x 156 x 6600 mm
Maximum weight of door 1 leaf: Maximum weight of door 2 leaves:	SL4A = 1 x 100 kg SL5A = 1 x 140 kg SL4A = 2 x 90 kg SL5A = 2 x 120 kg	SL4E = 1 x 100 kg SL5E = 1 x 140 kg SL4E = 2 x 90 kg SL5E = 2 x 120 kg

Features	SLTA	SLTE
Automation type	TELESCOPIC-ADVANCED	TELESCOPIC-EMERGENCY
Certification	 <p>Type tested DIN EN 16005, DIN 18650-1/2</p> <ul style="list-style-type: none"> • open and close safe <p>ID P-4081/16</p>	 <p>Type tested DIN EN 16005, DIN 18650-1/2, AutSchR</p> <ul style="list-style-type: none"> • escape route safe • open and close safe <p>ID P-4082/16</p>
Max product dimensions: Height x Depth x Maximum length	125 x 216 x 6600 mm	125 x 216 x 6600 mm
Maximum weight of door 2 leaves: Maximum weight of door 4 leaves:	2 x 100 kg 4 x 70 kg	2 x 100 kg 4 x 70 kg

Features	ADVANCED	EMERGENCY
Maximum opening and closing speed:		
Sliding door 1 door	0,8 m/s	0,8 m/s
Sliding door 2 doors	1,6 m/s	1,6 m/s
Duty class	Continuous operation	Continuous operation
Intermittent operation	S3 = 100%	S3 = 100%
Power supply	100–240 Vca 50/60 Hz	100–240 Vca 50/60 Hz
Rated power / Stand-by	70 W / 10 W	70 W / 10 W
Rated load	150 N	150 N
Protection Rating	IP 20	IP 20
Operating temperature	 <p>-15 °C +50 °C</p>	 <p>-15 °C +50 °C</p>
Parameter Settings	Buttons and Display	Buttons and Display
Connections to control and safety devices	Dedicated connecting terminals	Dedicated connecting terminals
Power output for accessories	12 Vdc (1 A max)	12 Vdc (1 A max)
Memory for settings and saving	Micro SD standard	Micro SD standard
Electronic function selector	FSD1, FSD4	FSD1, FSD4
Bistable locking device	SL5LD	SL5LD
Signal of lock position	SL5SL	SL5SL (required if SL5LD)
Battery power device	SL5BD, SL5BD1, SL5BD2	SL5BD2 (required)
Fixing device for sensor	SL5FS	SL5FS

Features	SL5H – SL6H	SL6B
Automation type	HEAVY	BIG
Max product dimensions: Height x Depth x Maximum length	125 x 156 x 6600 mm	125 x 156 x 6600 mm
Maximum weight of door 1 leaf: Maximum weight of door 4 leaves:	1 x 180 kg 2 x 150 kg	1 x 400 kg 2 x 250 kg
Maximum opening and closing speed: Sliding door 1 door Sliding door 2 doors	0,6 m/s 1,2 m/s	0,3 m/s 0,6 m/s
Duty class Intermittent operation	Intensive operation S3 = 60%	Intensive operation S3 = 60%
Power supply Rated power / Stand-by	100–240 Vca 50/60 Hz 70 W / 10 W	100–240 Vca 50/60 Hz 70 W / 10 W
Rated load	150 N	350 N
Protection Rating	IP 20	IP 20
Operating temperature	 -15 °C  +50 °C	 -15 °C  +50 °C
Parameter Settings	Buttons and Display	Buttons and Display
Connections to control and safety devices	Dedicated connecting terminals	Dedicated connecting terminals
Power output for accessories	12 Vdc (1 A max)	12 Vdc (1 A max)
Memory for settings and saving	Micro SD standard	Micro SD standard
Electronic function selector	FSD1, FSD4	FSD1, FSD4
Bistable locking device	SL5LD	SL5LD
Signal of lock position	SL5SL	SL5SL
Battery power device	SL5BD, SL5BD1, SL5BD2	SL5BD, SL5BD1, SL5BD2
Fixing device for sensor	SL5FS	SL5FS

Features	SL6HA	SL6HB
Automation type	HEAVY	BIG
Max product dimensions: Height x Depth x Maximum length	125 x 156 x 6600 mm	125 x 156 x 6600 mm
Maximum weight of door	1 x 100 kg	1 x 200 kg
Maximum opening and closing speed	0,8 m/s	0,3 m/s
Duty class Intermittent operation	Intensive operation S3 = 60%	Intensive operation S3 = 60%
Power supply Rated power / Stand-by	100–240 Vca 50/60 Hz 70 W / 10 W	100–240 Vca 50/60 Hz 70 W / 10 W
Rated load	150 N	350 N
Protection Rating	IP 20	IP 20
Operating temperature	 -15 °C  +50 °C	 -15 °C  +50 °C
Parameter Settings	Buttons and Display	Buttons and Display
Connections to control and safety devices	Dedicated connecting terminals	Dedicated connecting terminals
Power output for accessories	12 Vdc (1 A max)	12 Vdc (1 A max)
Memory for settings and saving	Micro SD standard	Micro SD standard
Electronic function selector	FSD1, FSD4	FSD1, FSD4
Safety braking device	SL5SB4	SL5SB4
Battery power device	SL5BD, SL5BD2	SL5BD, SL5BD2

Features	SL3L
Automation type	LIGHT
Max product dimensions: Height x Depth x Maximum length	100 x 148 x 6600 mm
Maximum weight of door 1 leaf: Maximum weight of door 2 leaves:	1 x 70 kg (S3 = 100%) 2 x 50 kg (S3 = 100%) / 2 x 60 kg (S3 = 80%)
Maximum opening and closing speed: Sliding door 1 door Sliding door 2 doors	0,8 m/s 1,6 m/s
Duty class Intermittent operation	Continuous operation S3 = 100% (2 x 50 kg) / S3 = 80% (2 x 60 kg)
Power supply Rated power / Stand-by	100–240 Vac 50/60 Hz 60 W / 8 W
Rated load	80 N
Protection Rating	IP 20
Operating temperature	 -15 °C  +50 °C
Parameter Settings: basic settings and advanced settings	Buttons and Display
Connections to control and safety devices	Dedicated connecting terminals
Power output for accessories	12 Vdc (1 A max)
Memory for settings and saving	Micro SD standard
Electronic function selector	FSD1, FSD4
Locking device	SL3LD, SL3SB1
Battery power device for emergency opening	SL3BD1
Fixing device for opening and safety sensor	SL3FS

Note: The technical data above refer to average conditions of use and cannot be certain in each case. Each automatic entrance variables such as: friction, balancing and environmental conditions may substantially change both the duration and the quality of the operation of the automatic entrance or some of its components, including the automation. The installer must adopt adequate safety coefficients for each particular installation.

4. FUNCTION SELECTOR FSD1 USE

You can use the function selector to select the operating mode of the automatic sliding door.

The function selector can work in the following ways:

- Always active and usable by all (factory setting);
- Selecting for 3 seconds the logo, the function selector is activated for 10 seconds, after that time the function selector turns off to prevent inadvertent operation;
- Approaching the badge to the NFC symbol (FSD1), or by entering the numeric code (FSD4), the function selector is activated for 10 seconds, after that time is turned off to prevent its use by unauthorized personnel.

Note: the type of use and the desired storage of the badge (FSD1) and numeric codes (FSD4), must be performed in the installation phase.

The function selector allows the following settings.

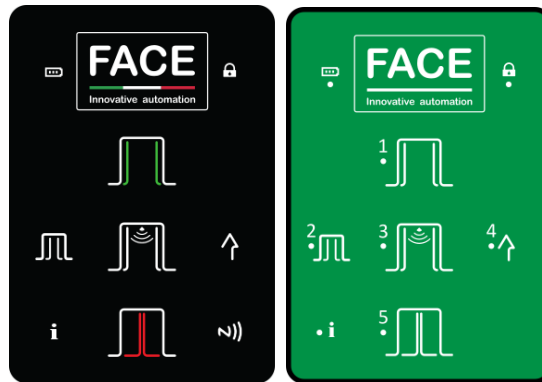

Symbol	Description
	OPEN DOOR When selected, the symbol lights up, the door is permanently open. Note: the leaves can still be handled manually.
	AUTOMATIC BI-DIRECTIONAL OPERATION When selected, the symbol lights up, the door works automatic in bidirectional mode. RESET Select the symbol for 5 seconds, the automation performs the self-test and the automatic learning.
	CLOSED DOOR When selected, the door is permanently closed. If the locking device is present, the door is closed and locked. Note: using the menu SEL > DLAY you can adjust the delay time to close the door. CLOSING PRIORITY Select the symbol for 3 seconds, the automation closes slowly in "Low energy" mode, and the safety devices are temporarily disabled.
	AUTOMATIC PARTIAL OPERATION When selected, the symbol lights up and automatic operation of the door is with a partial opening of the leaves.
	AUTOMATIC ONE-WAY OPERATION When selected, the symbol lights up and automatic operation of the door is in one-way mode.
	FUNCTION SELECTOR IS NOT ACTIVE The symbol lights up when the function selector is not active. To activate the temporary operation of the function selector is necessary to approach the badge to the NFC symbol (FSD1), or enter the code (FSD4), or select for 3 seconds the logo.
	ACTIVATION OF THE FUNCTION SELECTOR Select the logo for 3 seconds (the lock symbol light off), the function selector is activated for 10 seconds. Expired the time the function selector switches off (the lock symbol lights up).
	FSD1 - Authorized activation of function selector by badge. Approach the badge to the NFC symbol (the lock symbol light off), the function selector is activated for 10 seconds. Expired the time the function selector switches off (the lock symbol lights up). FSD4 - Authorized activation of function selector by numeric code. Press the logo, enter the code (maximum 5 numbers), press the logo for confirmation, (the lock symbol light off), the function selector is activated for 10 seconds. Expired the time the function selector switches off (the lock symbol lights up).
	BATTERY SIGNAL Battery symbol off = the door is operating with the mains supply Battery symbol on = the door is operating with battery power Battery symbol flashing = the battery is low or disconnected
	INFORMATION SIGNAL Information symbol on = it is necessary to perform the ordinary maintenance of the door. Information symbol flashing = shows the presence of alarms: - 1 flash = failure of electronic control or locking device; - 2 flashes = mechanical failure; - 3 flashes = failure of sensor safety test; - 4 flashes = motor overtemperature. - 5 flashes = failure of Emergency electronic control

5. MANUAL SLIDING DOOR USE

The FACE automations for automatic sliding doors are extremely reversible, and allow manual handling of the doors without additional effort.

The situations in which it is necessary to move the door manually are mainly two:

- For cleaning the doors, the glasses and external slides of the automation;
- In case of power failure or damage of the automation.

Note: in both cases, any latches and locks fitted on the doors should be opened.

5.1 MANUAL SLIDING DOOR USE FOR DOOR CLEANING OPERATION

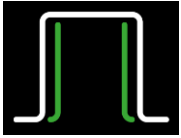

The manual handling of the sliding door is always possible, select the door open mode from function selector.

Note: in the absence of the function selector, you can keep the door open mode via a switch connected to terminals 1-KO of electronic control.

5.2 MANUAL SLIDING DOOR USE IN ABSENCE OF POWER SUPPLY OR IN CASE OF DAMAGE

The manual handling of the sliding door is always possible even in case of power failure, or in case of damage of the automation.

In the presence of SL5LD locking device, by pulling the release cord you unlock the door, and remains unlocked until it is restored the electrical operation.

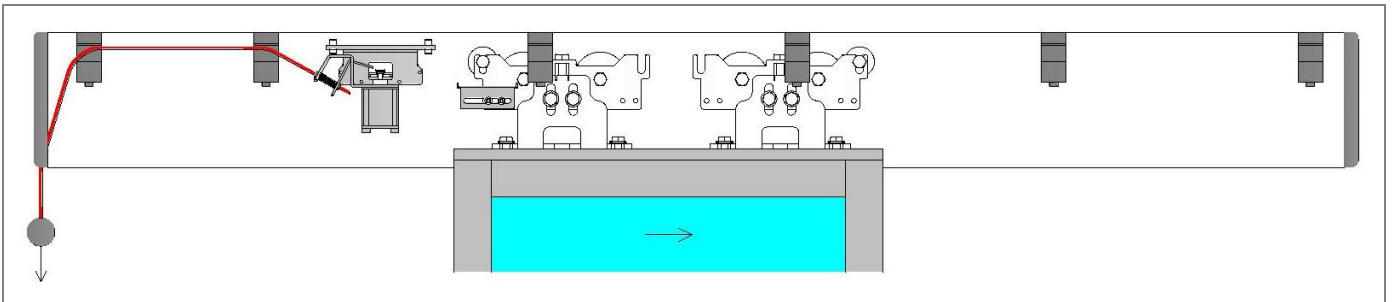

To remove the power supply, for example in case of automation failure, unplug it from the electricity near the automation, or turn off the isolating switch arranged in the electrical system.



6. MANUAL USE OF SLIDING DOOR WITH BREAK-OUT SYSTEM

If the automatic sliding door is an emergency exit door equipped with break-out system in escape direction, proceed as follows.

Make sure that the supplied labels are applied, in a visible location on each sliding door [a] in escape direction.

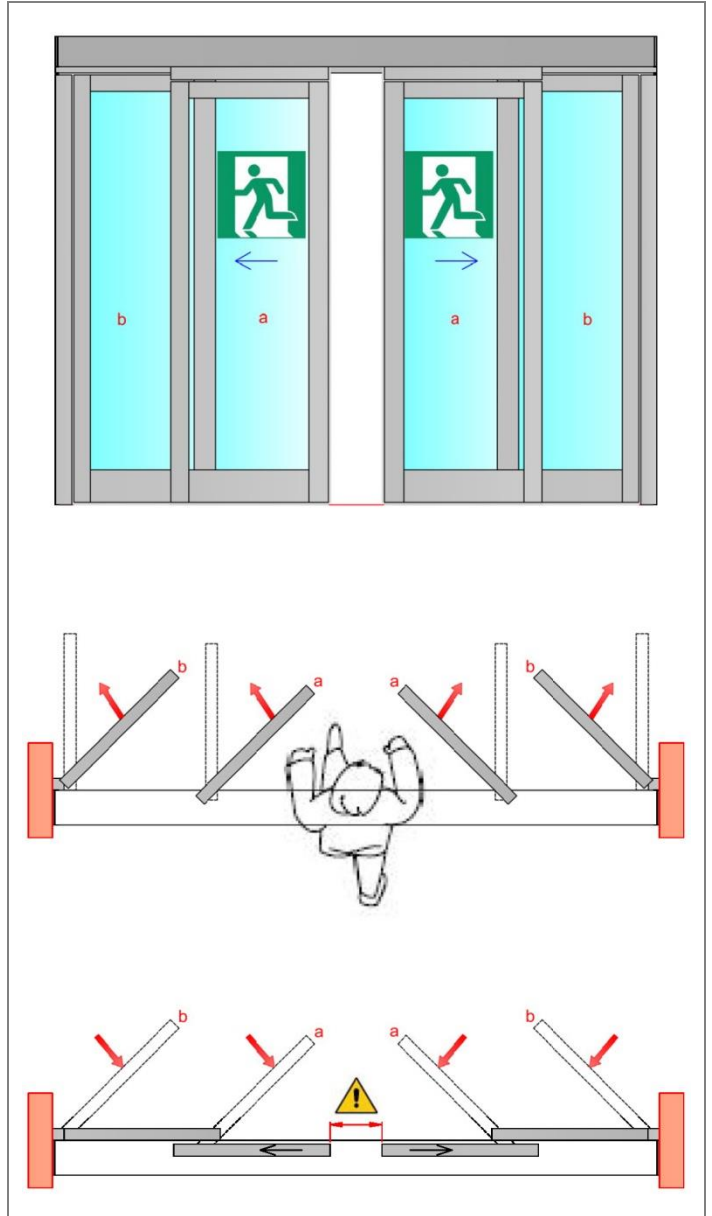

The sliding doors [a], and the side walls [b] break-out, is obtained by pushing the doors in the escape direction.

It's sufficient to apply a force not exceeding 220 N near the closing edge at 1 m height.

The doors break-out stops the automatic mode and the door can be just moved manually.

To restore the automatic sliding door operation:

- manually reposition the sliding doors [a] as initial position,



Attention: sliding doors should not be completely closed.

- manually reposition the side walls [b] as initial position, if present.

7. USING THE SLIDING DOOR FOR EMERGENCY EXIT (WITHOUT BREAK-OUT SYSTEM)

The EMERGENCY automation is used in emergency exits, and allows the automatic opening of the door in case of failure, in the absence of power, or in the case of signaling by an alarm system.

The door must be equipped with the OSD4, OSD7 sensor opening for emergency exits, installed in the direction of escape.



To keep the door closed and turn off the operation of the emergency exit, you need to install the FSD1, FSD4 function selector.

The function selector must be accessible only by authorized personnel, through the use of badges.

Note: every time you switch on, or every 24 hours, the emergency opening test is performed.



When required, the door must be equipped with an emergency opening device (EOD), installed in an easily identifiable and accessible position in the direction of the exit.

The emergency opening device allows immediate opening of the door, regardless of the position of the function selector device.

8. TROUBLESHOOTING

The following list of possible problems must be used by qualified personnel.

Problem	Possible causes	Remedy
The automation does not open or close.	No power supply (display off).	Check the power supply.
	Blow line fuse (display off).	Replace the mains fuse.
	Short circuited external accessories.	Disconnect all accessories from terminals 0-1 and reconnect them one at a time (check for voltage 12V).
	The door is locked by bolts and locks.	Check the freely move of the doors
The automation does not perform the functions set.	Function selector incorrectly set.	Check and correct the settings of the function selector.
	Control devices or safety always activated.	Disconnect devices from the terminal and verify the operation of the door.
The movement of the doors isn't linear, or reverse the movement for no reason.	The automation does not successfully perform the automatic learning.	Perform a reset using the command 1-29 , or power off and power on the automation.
The automation opens but does not close	Anomalies during the safety devices test.	Jumper contacts one at a time 41 -8A , 41 -8B , 41 - 6A, 6B - 41 .
	The opening devices are activated.	Verify that the opening sensors are not subject to vibration , do not perform false detections or the presence of moving objects in the field of action.
	The automatic closing doesn't work.	Check the settings of the function selector .
Safety devices not activating.	Incorrect connections between the safety devices and electronic control.	Check that the safety contacts of the devices are properly connected to the terminal blocks and the relative jumpers have been removed.
The automation opens by itself.	The opening and safety devices are unstable or detect moving bodies	Verify that the opening sensors are not subject to vibration , do not perform false detections or the presence of moving bodies in the field of action.
	The EMERGENCY automation is testing the emergency opening.	Wait for the test run.
	The EMERGENCY automation has detected a fault.	Check for the presence of the power supply. Check the connection of the battery and its efficiency. Check the contact closure 1-E0. Make sure that the function selector device is in protected mode (the padlock symbol should be lit). If present, check the position of the locking device and the connection 1-S1.
The locking device doesn't lock or unlock the doors.	Wrong connection of the locking device to the electronic control.	Check the correct color connection of the locking device
	The attachment lock brackets, fixed on carriage, will not release	Check the adjustment of the position of the brackets coupling lock.
	Pulling the release cord don't unlock the doors.	Check the correct fitting of the release cord on the lock.

9. WARNINGS ON THE ELECTRONIC CONTROL DISPLAY AND ON THE FUNCTION SELECTOR

Warnings on the electronic control display must be used by qualified personnel.

DISPLAY	SEL	FLASH	WARNING	CHECK
W001		1	Encoder error	Check encoder connection
W002		1	Motor short circuit	Check the connection of the motor
W003		1	Motor control error	Electronic control failure
W010		2	Direction reversed	Check the presence of obstacles
W011		2	Running too long	Check the connection of the belt
W012		2	Running too short	Check the presence of obstacles
W013		2	Overrun	Check the mechanical stops
W030		5	Emergency card not detected	Electronic control failure
W031		5	Communication interrupted	Electronic control failure
W032		5	Emergency sensor input failure	Electronic control failure
W033		5	Failure test of emergency opening	Check the connection motor - electronic control
W034		5	Relay motor error	Electronic control failure
W035		5	Error lock position	Check the lock and microswitch connections
W036		5	Error of lock operation	Check the lock and microswitch connections
W037		5	Opening door failure	Check the presence of obstacles
W038		5	Failure test of emergency opening	Check the connection motor - electronic control
W039		5	Contact 1-KC closed more than 10 seconds	Check the connection to the terminal KC
W100	-	-	Programming error (CB01)	Repeat the programming procedure in MEM > FW menu
W103	-	-	Programming error (FSD1)	Repeat the programming procedure in SEL > FW menu
W104	-	-	Programming error (CB02)	Repeat the programming procedure in MEM > FW menu
W127	-	-	Automation reset	The automation performs a self-test
W128		on	No power supply	Check the power supply
W129		1	No battery	Check the battery connection
W130		1	Low Battery	Replace or recharge the battery
W140		3	6A safety test failure	Check the safety sensor connection
W141		3	6B safety test failure	Check the safety sensor connection
W142		3	8A safety test failure	Check the safety sensor connection
W143		3	8B safety test failure	Check the safety sensor connection
W145		4	Motor overtemperature (first step)	The door reduces the speed
W146		4	Motor overtemperature (second step)	The door stops
W148		1	Locking device overcurrent	Check the ADV > TYLK menu and the lock connection
W150		2	Obstacle in opening	Check the presence of obstacles
W151		2	Obstacle in closing	Check the presence of obstacles
W152		2	Door locked open	Check the presence of locks
W153		2	Door locked closed	Check the presence of locks
W160		2	Synchronization error	Check the ADV > SYNC and ADV > INK menu
W256	-	-	Power on	-
W257	-	-	Firmware update	-
W320		on	Signaling of maintenance	Check the INFO > SERV menu
W330		1	Tuning between motor and electronics	Wait about 3-30 seconds

10. AUTOMATIC SLIDING DOOR ORDINARY MAINTENANCE PLAN

To ensure proper operation and safe use of the automatic door, as required by European standard EN16005, the owner has to perform routine maintenance by qualified personnel.

Except for routine cleaning of the door and any floor rails, that are under the responsibility of the owner, all maintenance and repair work must be carried out by qualified personnel.

The following table lists tasks related to routine maintenance, and the frequency of intervention related to an automatic sliding door operation with standard conditions. In the case of more severe operating conditions, or in the case of sporadic use of the automatic sliding door, the frequency of maintenance can be consistently adequate.

Task	Frequency
Remove the power supply, open the automation and perform the following checks and adjustments. - Check all screws fastening of components within the automation. - Check the cleanliness of carriage and rail. - Check the correct belt tension. - Check the state of belt wear and carriage wheels (if necessary replace them). - Check the correct fitting of the doors on the carriages . - If present, verify proper engagement of the locking device and the operation of the release cord.	Every 6 months or every 200.000 cycles.
Connect the power supply and perform the following checks and adjustments. - Check the correct operation of the control devices and safety. - Check the detection area of the security sensors complies with the requirements of the European standard EN16005. - Check the operating forces of the doors comply with the requirements of the European standard EN16005. - If present, verify the correct operation of the locking device. - If present, verify the correct operation of the battery power device (if necessary replace the battery).	Every 6 months or every 200.000 cycles. Note: the verification of the automation security functions and safety devices must be made at least 1 time per year.

All maintenance, replacement, repair, update, etc.. must be written into the proof book, as required by European standard EN16005, and delivered to the owner of the automatic sliding door.

For repairs or replacements of products, original spare parts must be used.

10.1 DISPOSAL OF PRODUCTS



The packaging materials (cardboard, plastic, and so on) should be disposed of as solid household waste, and simply separated from other waste for recycling.

Our products are made of various materials. Most of these (aluminum, plastic, iron, electrical cables) are classified as solid household waste. They can be recycled by separating them before dumping at authorized city plants.

Whereas other components (control boards, batteries, and so on) may contain hazardous pollutants.

These must therefore be disposed of by authorized, certified professional services.

Before disposing, it is always advisable to check with the specific laws that apply in your area.

DO NOT DISPOSE IN THE ENVIRONMENT.

FACE S.r.l.

Viale delle Industrie, 74 - 31030 Dosson di Casier (TV) – Italy

Fax +39 0422 380414 \ Phone +39 0422 492730

E-mail: info@facespa.it \ www.facespa.it



PROOF BOOK

FOR PEDESTRIAN AUTOMATIC DOORS

ACCORDING TO MACHINES DIRECTIVE 2006/42/CE AND EUROPEAN STANDARD EN 16005

This proof book contains technical references and records of installation, maintenance, repairs and alterations carried out and must be made available for any inspections by authorized bodies.

SPECIFICATIONS OF THE AUTOMATIC DOOR AND INSTALLATION

Manufacturer / Installer:

Name, address and reference person

Customer / Owner:

Name, address and reference person

Order number:

Number and date of customer order

Model and description:

Type of door

Dimensions and weight:

Doorway width, dimensions and weight of the leaves

Serial number:

Number for clear identification of the door

Location:

Address of installation

LIST OF COMPONENTS INSTALLED

The technical features and performances of the components listed below are documented in the relevant installation manuals and/or on the label on the component itself.

Drive unit:

Model, type, serial number

Motor:

Model, type, serial number

Electronic control:

Model, type, serial number

Safety devices:

Model, type, serial number

Control devices:

Model, type, serial number

Other devices:

Model, type, serial number

Other components:

Model, type, serial number

START-UP REPORT

Tick the box corresponding to the work made: C = Comply, NC = Not comply, NA = Not applicable.

Step	Description	C	NC	NA
1	Check the existing structure and the fixing of the automation			
2	Check the correct fitting of the leaves to the carriages and the adjustment			
3	Check that the carriages cannot get out from the sliding rail			
4	Check the adjustment of the belt tension			
5	Check of mechanical stops, and the fixing of all screws			
6	Check the guide on the floor			
7	Check that the opening is conforming to the customer request			
8	Check the gap between the leaf and the floor			
9	Check the safety gap between the leaf and fixed parts			
10	Manually checked that the leaves slide without friction			
11	Check of electrical connection of devices			
12	Check the detection area of the opening and safety sensors			
13	Check the additional opening controls (buttons, key contacts, etc.)			
14	Check the function selector			
15	Check the battery operation			
16	Check the locking device operation and the manual unlocking operation			
17	Check the opening and closing speed			
18	Delivered the declaration of conformity to the owner			
19	Delivered the user instructions to the owner			
20	Delivered the proof book to the owner			
Date	Technician's signature	Customer's signature		

DESCRIPTION OF THE WORK

Tick the box corresponding to the work carried out. Describe possible residual risks and/or foreseeable improper use.

- Installation
- Start-up
- Adjustments
- Maintenance
- Repairs
- Alterations

Date

Technician's signature

Customer's signature

DESCRIPTION OF THE WORK

Tick the box corresponding to the work carried out. Describe possible residual risks and/or foreseeable improper use.

- Installation
- Start-up
- Adjustments
- Maintenance
- Repairs
- Alterations

Date

Technician's signature

Customer's signature

DESCRIPTION OF THE WORK

Tick the box corresponding to the work carried out. Describe possible residual risks and/or foreseeable improper use.

- Installation
- Start-up
- Adjustments
- Maintenance
- Repairs
- Alterations

Date

Technician's signature

Customer's signature

DECLARATION OF CONFORMITY

Machines Directive 2006/42/EC, Annex II-A



Manufacturer: _____
Address: _____

DECLARES THAT:

The Product: _____
Location: _____

It complies with the Machines Directive 2006/42/EC.

It complies with the Electromagnetic Compatibility Directive 2014/30/UE.

It complies with following harmonized standards:

EN 16005 Power operated pedestrian doorsets - Safety in use - Requirements and test methods

The technical documentation is managed by:

Name: _____
Address: _____

Place and date: _____
Name: _____
Position: _____
Signature: _____